

MULTIMIX 8/4 DIGITAL AUDIO-PROCESSING

8 IN AND 4 OUT

...and in between, the most extensive professional audio signal processing
- a sound engineer's dream come true!

 **ITEC**
www.itec-audio.com

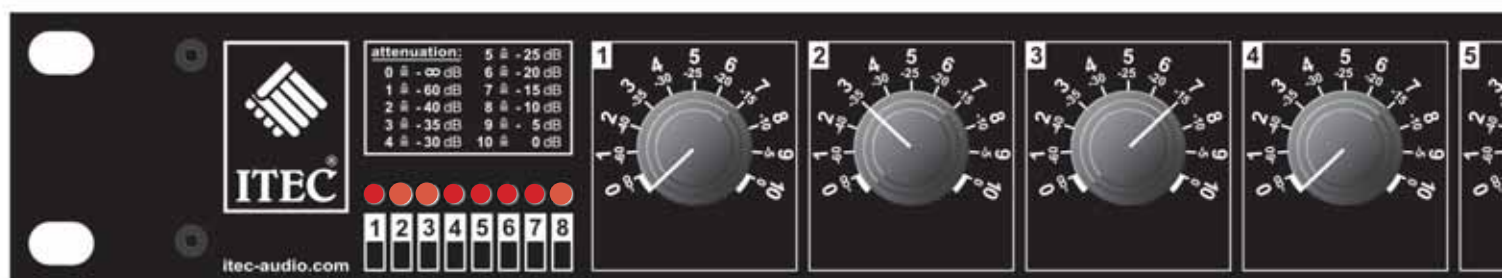

Aim

The most important aim of our development efforts is to create products that fit our customer's requirements while simultaneously pleasing planning and technical personnel through simple and effective installation and configuration. Many years of hands-on experience in audio processing and sound projection have taught us the essential requirements: a multifunctional device that provides the sound engineer with extensive possibilities for signal processing on one hand while on the other hand providing the user with as user-friendly an interface as possible. The new ITEC MULTIMIX 8/4 digital is also exceptionally flexible. It is competitively priced, making it affordable for simple, small-scale sound reinforcement systems. Because of its open architecture, cascading ability and superb quality, it is also an ideal choice for complex, large-scale installations. Installation and configuration of the mixer remains self-explanatory and simple in all types of application. The configuration software ITEC MIXDESIGN is easy to learn and is supplied free of charge with the device.

Features

Unlike comparable products, the ITEC MULTIMIX has an analogue, but fully digitally controlled signal part. Two processors manage the voltage controlled amplifiers (VCAs), measure levels and transducer signals and switch the signal paths. The analog signal path concept is a decisive factor in the devices' exceptional sound quality, especially their outstanding signal-to-noise ratio and dynamics and their low harmonic distortion of low signal levels. Each of the eight input channels can be applied to one or more of the four internal bus lines. In devices without DSP module, the bus is identical with the corresponding output. The DSP module enables signal processing for each separate bus signal prior to adding the signals to the output channels. The ITEC MULTIMIX can store up to 15 complete configuration sets in its flash memory, which users can load as required.



Auto-Mixing

The ITEC MULTIMIX features an integrated automatic microphone mixer as standard. At ITEC we are convinced that you cannot manage a larger number of microphones without this feature. The sophisticated algorithm guarantees a precise detection of the microphones that are in use, even at high ambient noise levels and suboptimal microphone positioning. To prevent acoustic feedback, a NOMA (number of open microphones attenuator) automatically reduces the overall volume level depending on the number of active microphones. All important auto mixing parameters (number of open microphones, inactive input reduction, hysteresis, etc. are configurable. This allows for perfect matching of the device to the microphones used and to the venue's particular acoustic characteristics.

Voice Over Music (VOM)

One or more channels can be defined as trigger inputs. As soon as a signal is detected on any of these channels, the volume on all other channels is reduced to a defined level. Can be used, for example, as a ducking function to reduce music playback volume during voice announcements).

Priority

One or more channels are defined as priority inputs. As soon as a signal is detected on one of these channels, all other channels are muted. Can be used, for example, for urgent announcements or alarm signals. This feature works in parallel with and has priority over VOM.

Compressor-Limiter

Each input channel is equipped with a digitally managed analogue compressor/limiter with all common features and settings.

DSP-Module:

Optional feature, see page 7/12 MULTIMIX 8/4 digital

Input EQ Module:

Optional feature, see page 7/12 MULTIMIX 8/4 digital



Controls and display elements

The rotary switches on the front panel of the ITEC MULTIMIX 8/4 digital provide fast and simple volume control. This is a considerable advantage over comparable devices and represents the only possibility to implement a truly user-friendly stand-alone solution. Each volume control can be freely assigned to one or more inputs – useful, for example, to control both channels of a stereo signal with a single switch. In addition, the bandwidth (minimum/maximum volume) for each control is adjustable. The front panel features a status display consisting of eight LEDs. Their function is also user-definable, for example to indicate the signal or peak levels for each channel or to provide a single level meter for a single input or output channel. In automatic mixing mode, the LEDs provide indication for the active microphones.

Digital interfaces

Two independent RS 232 interfaces enable communication with external devices. The 9-pin interface located on the front panel can be used to connect a PC. The software ITEC MIXDESIGN transforms any PC or laptop into a full-featured MULTIMIX configuration console. The second 9-pin interface – on the device's rear panel – can be used to connect a media remote control system.



Inputs

The device has eight symmetrical inputs in the form of XLR sockets on the back panel. The maximum input gain can be selected individually for each input to ensure optimal adjustment for all common microphones and auxiliary playback devices. The maximum amplification range is -20 to +20 dB in Line mode and +10 to +50 dB in Mic mode. Phantom power can be applied to each channel on demand, with a default voltage of 12 V. With an optional phantom power module this can be increased to 24 V or 48 V.

Outputs

The device has four symmetrical outputs in the form of XLR sockets on the back panel. The maximum output level is +20 dB (if equipped with DSP module: +10 dB). In addition, the four bus signals are symmetrically available via an RJ45 connector. This allows cascading of multiple ITEC MULTIMIX devices.

External control

The remote control connector (25-pin connector on the back panel) provides remote volume control. The eight control inputs can be used with external potentiometers or a 0–10 V DC signal. The input or output controlled by each input is user-definable. The same connector includes inputs for switching configuration sets, allowing remote selection of any of the 15 saved configuration sets.

Device status outputs (Fault contacts)

The device features a floating device status output, through which internal faults can be signalled.

LAN-Module (Option)

Versions with the optional built-in Ethernet LAN module can be remotely configured, maintained and controlled through the TCP/IP protocol.

MultiMix 8/4 Diagram

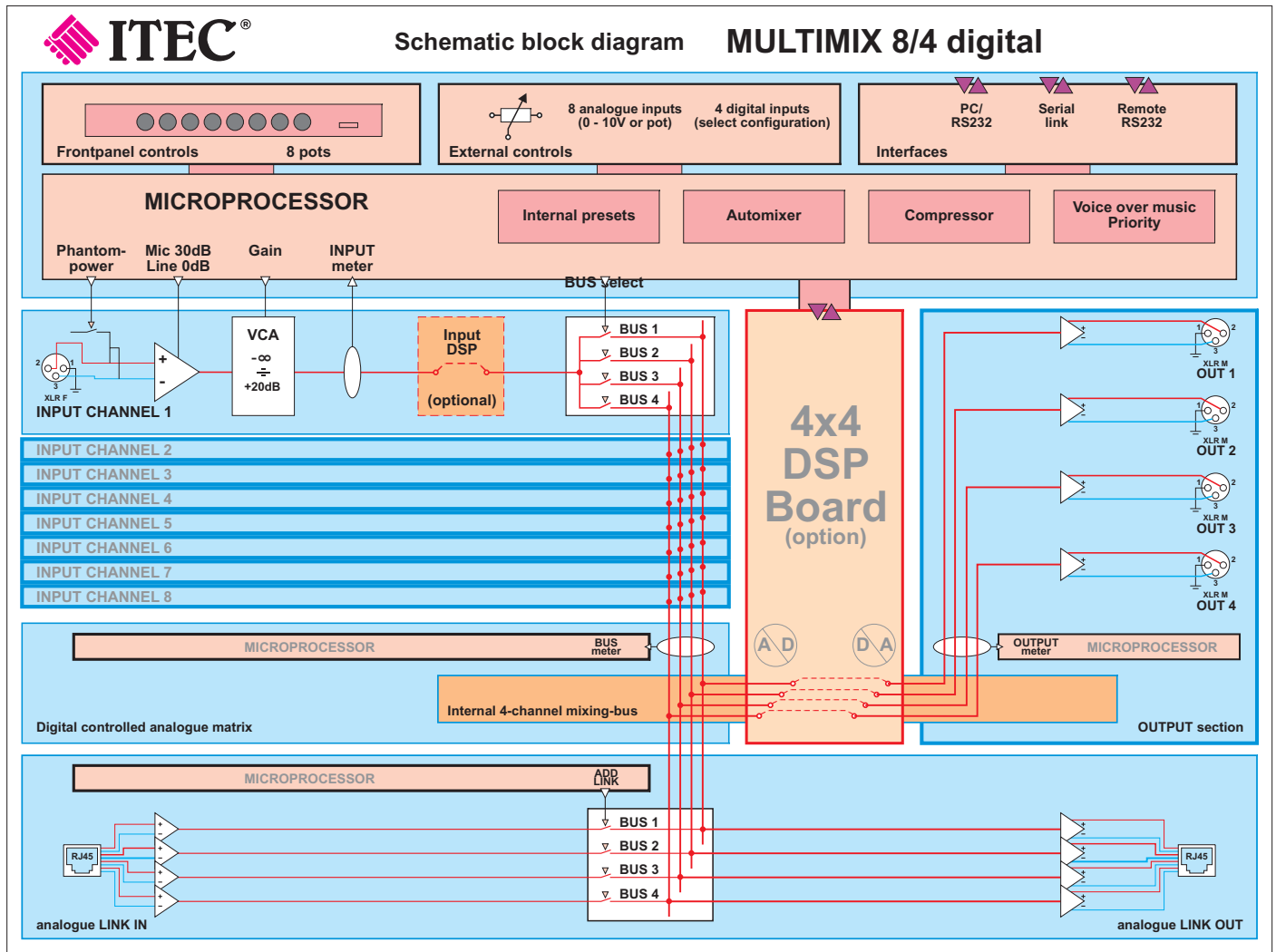

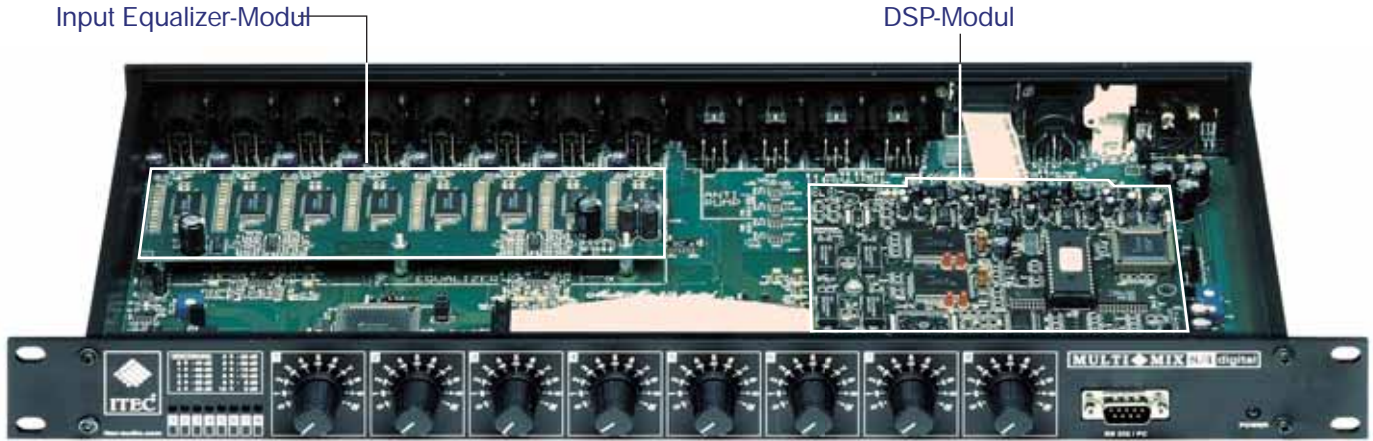

DSP-Module

An optional 4x4 DSP module can be integrated into the mixer. The configuration software for the DSP module is incorporated in ITEC MIXDESIGN and is just as easy to use as the rest of the software. The DSP operates in 24-bit/44.1 kHz mode and is equipped with the most suitable algorithms. The DSP provides nine fully parameterizable filters for each input. The quality and frequency of the filters can be adjusted to fit individual requirements. The 4x4 matrix allows mixing of the four processed signals with the four outputs in steps of one dB. Furthermore, each output is equipped with a delay (from 0.023 to 500 ms) and a band pass filter (1st to 4th order).

DSP Blockdiagram

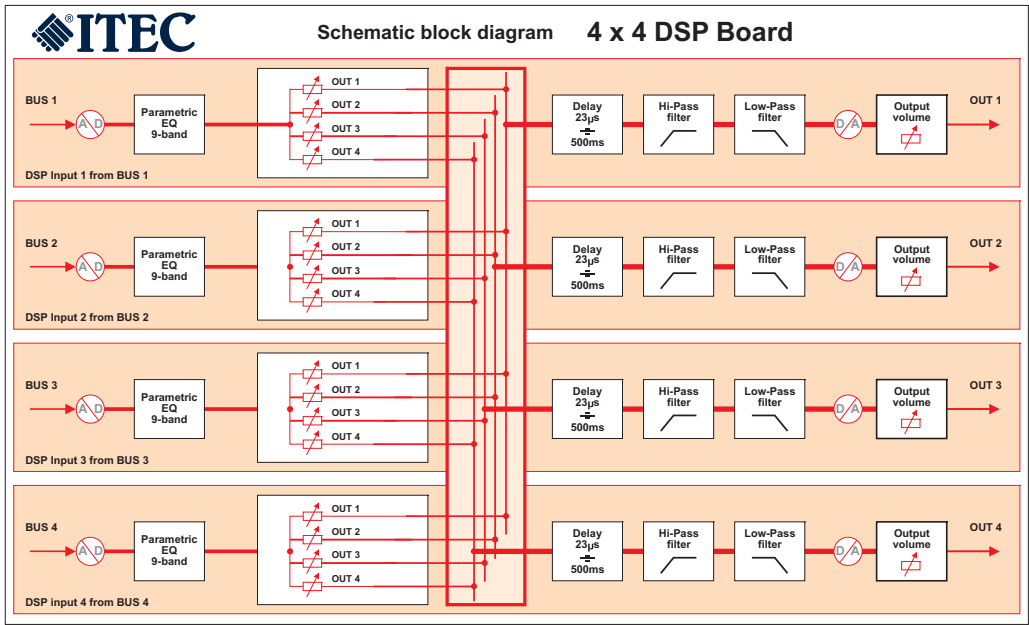

Input Equalizer Module

The optional input equalizer module provides further sound processing functionality at the inputs. Each input receives a 7-band graphic equalizer with octave-band level adjustment from -10 to +10 dB at 2 dB steps.

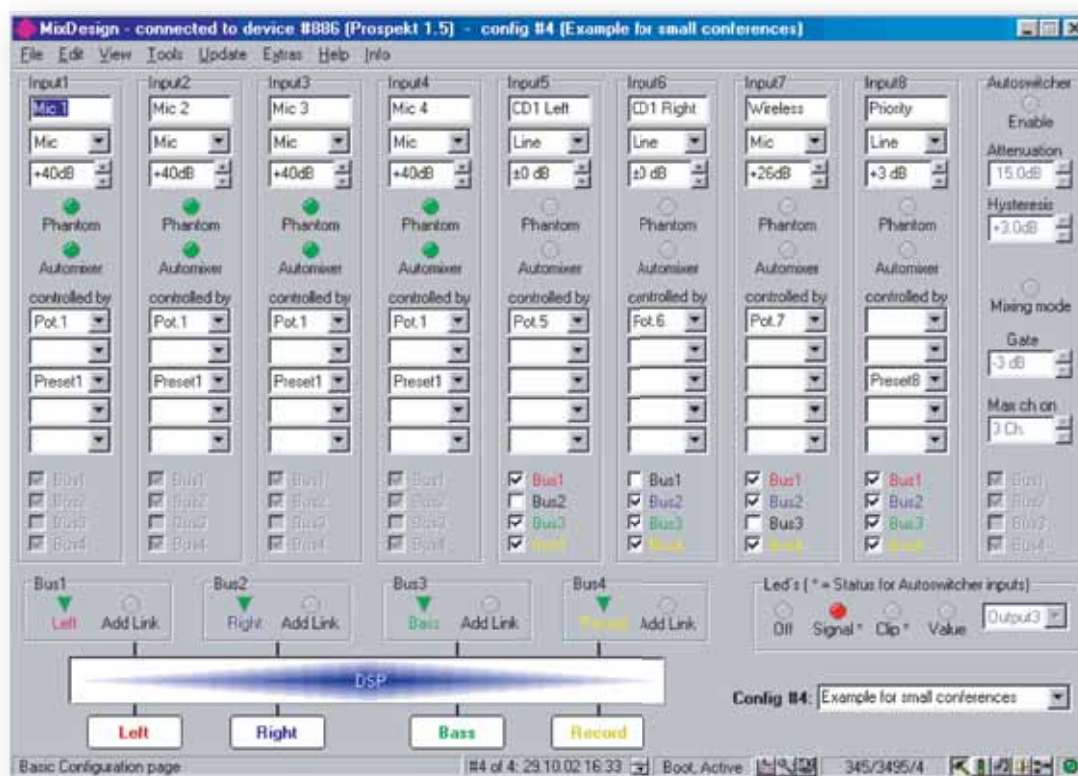

ITEC MIXDESIGN PC Software for the ITEC MULTIMIX 8/4 digital

The MIXDESIGN software is the sound engineer's interface to the Multimix. It is used to define the default settings and to test the mixer's function in operation. A key feature of this tool is that all adjustments take effect in real time, so that any changes can be heard immediately. The settings are saved to the Multimix controller's flash memory, where they are safe from power failures. The stored configuration includes all necessary settings and parameters as well as any user-defined input and output designations. This allows engineers to quickly recall the data for the last configuration. Up to 15 complete configurations can be saved and loaded again with a selector switch.

Configuration with a click

All basic settings – pre-amplification (mic/line), volume controls, allocation of outputs and the parameters for auto mixing – are made on a single, clearly-structured screen.

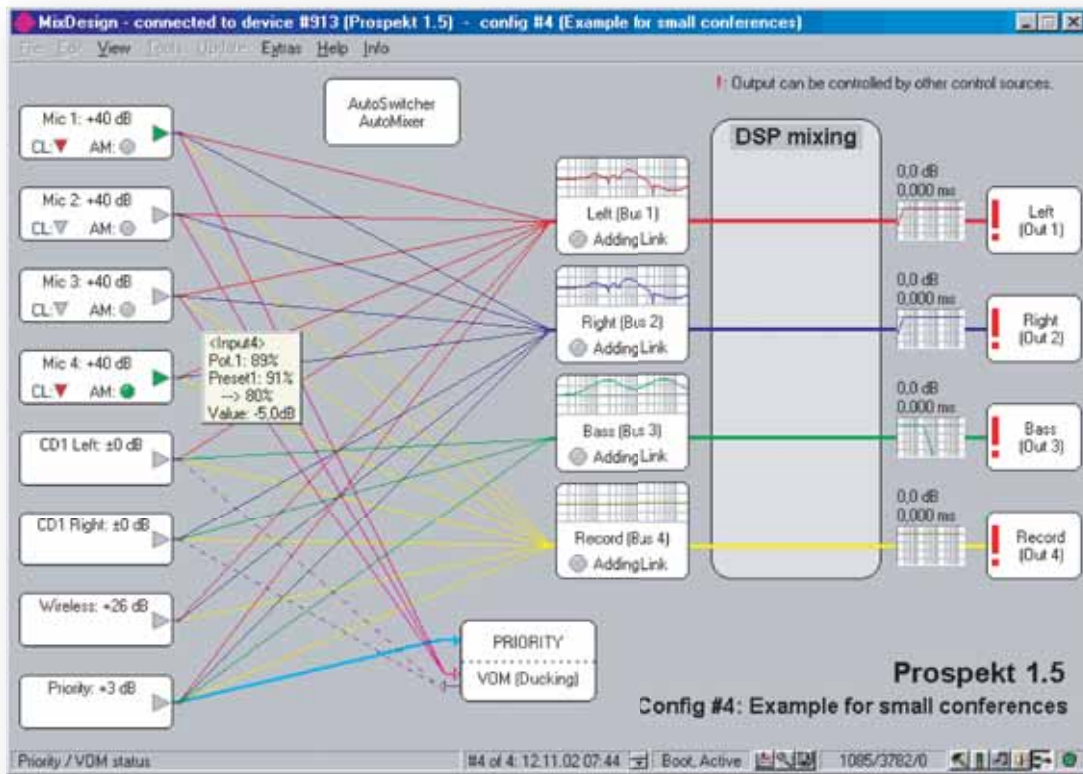

Configuration diagram

The VIEW/CONFIGURATION function provides a clear overview of the active configuration. Coloured lines indicate the allocation of inputs, and the settings are displayed in fields. Current levels and additional information can be viewed by clicking on each label.

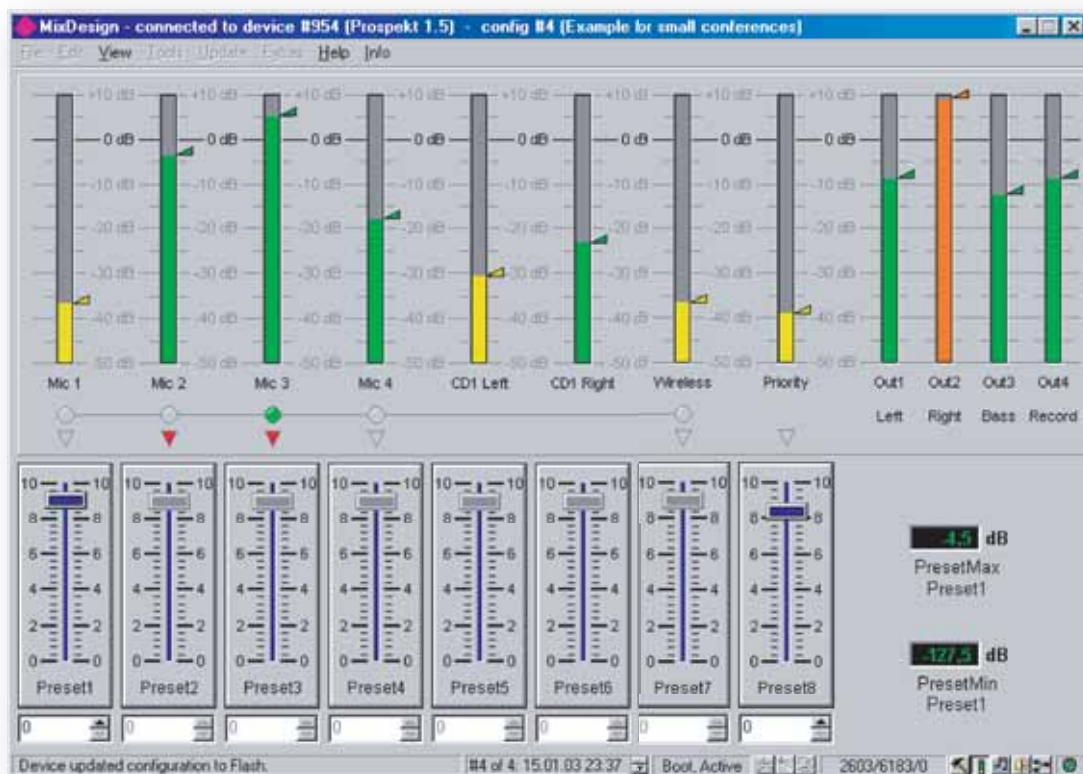

All levels at a glance

The VIEW/VU-meters, internal presets screen displays the current levels of all inputs, outputs and buses. This feature allows the technician to check the effect of the current settings at a glance and to adjust the eight internal volumes.

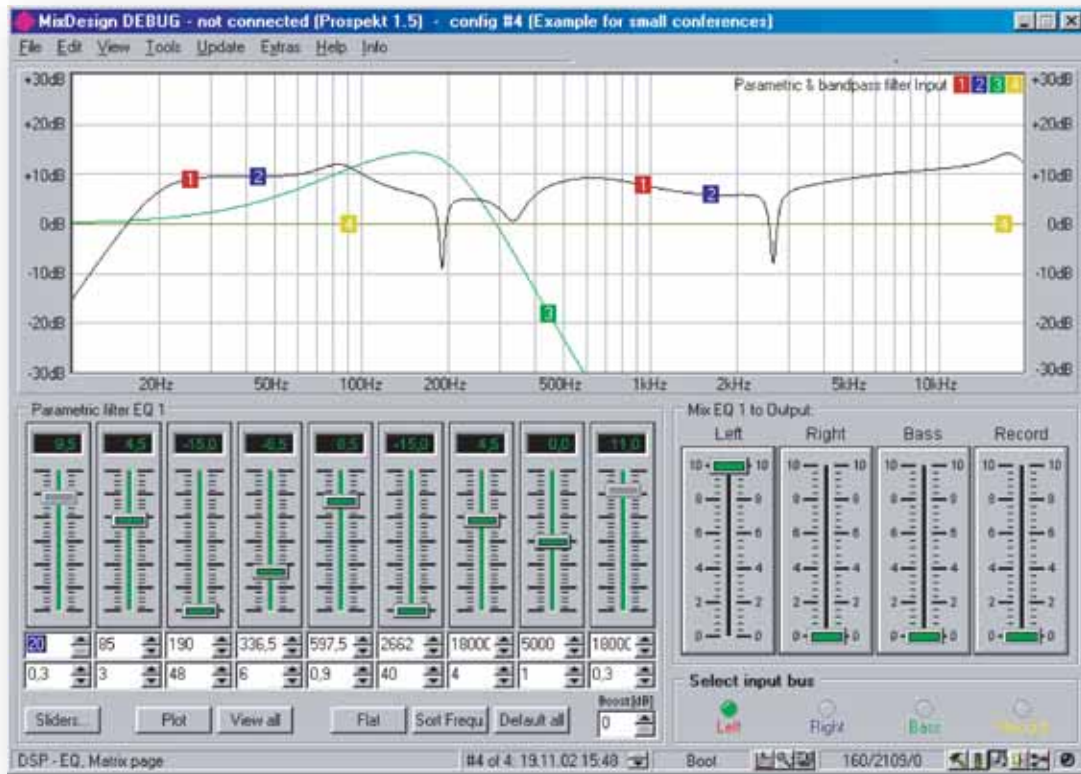

Digital Signal Processing (DSP)

Every ITEC MULTIMIX 8/4 can be equipped with an optional DSP module. Such a module provides a great deal of the most important audio processing features like delays, a 9 band parametric equalizer, filters, a 4x4 matrix etc. The user friendly software MIXDESIGN supports you in choosing and configuring the DSP module. You can wire together a whole set of professional audio processing units with the mixer with just a few mouse clicks. The filter settings can be displayed as a diagram and are effective immediately in online mode.

MULTIMIX 8/4 DIGITAL - SPECIFICATIONS



GENERAL

Frequency response	20 Hz - 20 kHz / -1 dB
Harmonic distortion	< 0.005%
Overall dynamics	103 dB
POWER SUPPLY	External power supply unit
Input	115 – 230 V AC
Output	+12 V, -12 V, +5 V/20 W
INPUTS	Symmetrical; max. amplification configurable from -20 dB to +50 dB
Phantom power	+12 V, with option for +24 V or +48 V
Input impedance	6.6 kohm
OUTPUTS	Symmetrical; max. output levels +20 dB
Output impedance	Symmetrical 300 ohm, unsymmetrical 150 ohm
DIMENSIONS	482 × 44 × 180 mm (W x H x D), 19" 1 HU
WEIGHT	2.40 kg

DSP MODULE

GENERAL	24 bit, 96 kHz
	4 inputs, 4 outputs
	4 × 4 matrix
EACH INPUT	9-band fully parametric equalizer ±15 dB
Centre frequency	Configurable from 20 Hz to 20 kHz
Filter quality	Configurable from 0.1 to 70
EACH OUTPUT	Delay: 0.023 – 500 ms, band pass filter: 1 st – 4 th order

INPUT EQ MODULE

GENERAL	8 analogue inputs and outputs
	Pluggable PCB module
	Microprocessor-controlled
EACH INPUT	7-band graphic equalizer ±10 dB in 2 dB steps

LAN-MODUL

INTERFACE	Ethernet 10Base-T or 100 Base-TX (auto-sensing, full/half duplex)
PROTOCOLS	TCP/IP, UDP/IP, ARP, ICMP, SNMP, TFTP, Telnet, DHCP, HTTP Internet Web Server

MIXDESIGN SOFTWARE

You can download the current version of our software from: <http://www.itec-audio.com/download/mixer/mixersetup.exe>
 For information about our other product, contact us at office@itec-audio.com or www.itec-audio.com